

The Geoff Egan Memorial Lecture 2012

Surprises from the soil: archaeological discoveries from England's first successful transatlantic colony at Jamestown

By BEVERLY A. STRAUBE

SUMMARY: Archaeological excavations since 1994 have been uncovering the remains of James Fort in Virginia, the initial site of England's Jamestown colony, established in 1607. Recovered from closely dated contexts that are associated with documented historical events, the material culture is revealing new and interesting information about the early settlement. The objects reflect the colonists' interaction with the Virginia Indians, the activities of specialists sent to turn New World resources into profit for the colony's investors, as well as the choices that individuals made as they transported domestic goods across the Atlantic.

INTRODUCTION

From the very first spade of earth turned by the Jamestown Rediscovery archaeological project in 1994, it became clear that the English colony established in Virginia in 1607 had not yet given up all its secrets. Coming to light were numerous sherds of Surrey-Hampshire Border ware, Venetian glass beads traditionally associated with 16th-century Spanish settlements, Nuremberg casting counters, evidence of alchemical trials, and a large number of elements from arms and armour.¹ After disappearing from the landscape approximately 370 years earlier, James Fort had been found. But it would take another decade of excavations to determine that most of the perimeter of the original triangular fortification had survived despite the erosive forces of the nearby James River (Fig. 1).

During the early years of the colony, the one-acre fort enclosed within wooden palisade walls was densely occupied by the first settlers as it offered protection from sporadic attacks by hostile groups of Virginia Indians. The fort remained the

nucleus of the colony into the 1620s, and contained the domiciles of the early governors as well as the sites of the first churches, wells, and storehouses. This concentration of activity in one small area over two decades is reflected in the more than two million artefacts that now comprise the Jamestown Rediscovery collection (Fig. 2). Ironically, the richness of the material record can be attributed in large part to the settlement's high mortality rate and the concomitant rapid turnover of the populace as new settlers were sent to replace those who had died. Death released a great deal of personal property that was of little value or interest to the survivors, who were often close to becoming fatalities themselves, or who were suffering a general malaise from a combination of physical and psychological deprivations.²

Particularly useful for close dating of fort-period deposits are the historically documented clean-up and rebuilding efforts that served to bury thousands of artefacts in wells, trash pits, ditches, and cellars. These activities were often associated with the arrivals of the colony's new governors



FIG. 1

Aerial view of the James Fort site with a graphic reconstruction of some of the buildings located archaeologically (graphic, Jamie May).



FIG. 2

The Jamestown Rediscovery collections storage area known as the Vault (photograph, Michael Lavin).

and/or followed catastrophic events such as the January 1608 fire that destroyed fort structures and provisions, and the 1609–10 ‘starving time’ winter and spring when the Powhatan Indians held the fort under a six-month siege. As a result, the artefact assemblage presents reflections of life in very short definable moments of the early settlement. Geoff Egan, who once described the range and extent of the artefacts as ‘mind boggling’, was an enthusiastic advocate for the research value of James Fort’s material culture. In an article for *British Archaeology* concerning the findings of the Jamestown Rediscovery project, he wrote:

As much as anything, it is this concentration and scope of mainly English early 17th-century material from such a small area that makes the archaeological results so important. Such a chronological focus, with an extensive range of military, domestic and industrial evidence . . . cannot be paralleled at any one site in England.³

Geoff realized the value of the finds being recovered from the small Virginia island in the James River, not only for understanding the colony and its Atlantic world context, but also for what it could reveal about early 17th-century England and, more specifically, about early 17th-century London. The nascent Jamestown colony was administered and bankrolled from London, was predominantly supplied by London merchants, and was largely populated by individuals from London and its environs. In essence, while Jamestown was a colony of the Virginia Company of London (1607–24), it was in many ways a microcosm of the City. The evidence emanating from the James Fort excavations is therefore invaluable for informing research on contemporary London contexts, from which the recovery of material culture has been largely affected by centuries of land reclamation activities and modern-day development with deep subterranean structures.⁴

Geoff served as a consultant for the Jamestown Rediscovery project from his first Jamestown visit in the fall of 1995 until his untimely death fifteen years later. During that time, he and I worked closely together to identify and contextualize many obscure and enigmatic objects unearthed by the archaeologists’ trowels. This paper will discuss some of the many ‘surprises from the soil’ that delighted Geoff, as well as some that he unfortunately never had the opportunity to see. The few objects that follow provide just a sampling of the cultural and historical insights to be derived from the rich James Fort assemblage. This work has just begun.

SUPERFLUOUS TO THE COLONY?

Jamestown was established by the Virginia Company, a joint-stock enterprise of London-based entrepreneurs who hope to make quick returns on their investments, under charter from James I. To that end, almost 300 men arrived in the colony in the first two years following the initial May 1607 settlement. Many were gentlemen, including some Company shareholders, who hoped for personal profit by being present when the riches of the New World were discovered. These individuals paid for their own transportation as well as for that of their servants, but the Company subsidized the transatlantic passage for many labourers and specialists who were employed to extract any marketable resources the land had to offer.

With all the initial attention on resource exploitation, there was little time and energy expended on activities required to sustain the colony such as farming, fishing, and hunting. The Company expected that the Virginia Indians, particularly the local Powhatan, would be willing participants in an active sustainable trade whereby the colonists could regularly acquire victuals in exchange for a few inexpensive glass beads, pieces of copper, and cheaply-made iron tools. This plan worked sporadically but was never totally successful as the Indians soon tired of the Englishmen’s persistent reliance on them for sustenance during a period of severe drought when they also suffered food shortages.⁵ Tensions between the two groups erupted in the fall of 1609 in what has become known as the first Anglo-Powhatan war, which resulted in an effective Indian siege of James Fort that contributed to the ‘starving time’ winter and spring and a concomitant mortality rate of 75 per cent amongst the colonists.

Despairing of conditions in the colony, Captain John Smith complained about the Virginia Company’s drive for quick profits at the expense of the settlement’s welfare that ‘most plainly appeared by sending . . . so many Refiners, Gold-smiths, Jewellers, Lapidaries, Stone-cutters, Tobacco-pipe-makers, Imbroderers, Perfumers, Silkemen with all their appurtenances’.⁶ These occupations, seemingly superfluous to basic survival, have been used by historians through the years to depict the English settlement in a negative light, one even characterizing the endeavour as a ‘fiasco’.⁷ Indeed, the Virginia Company appears to have underestimated the number of individuals needed as a brute labour force to provide the colony’s infrastructure and it definitely miscalculated the quantity of victuals required to sustain a non-agricultural workforce. However, the initial years of the colony were full of optimistic experimentation and a variety of specialized craftsmen were considered necessary to

assess Virginia's resources for viability and profitability. Whereas some historians claim that most of these individuals stopped working once it was discovered that there were no resources to which they could apply their particular skills, the archaeological excavations of James Fort have been uncovering tools and by-products of various endeavours revealing that, at least to some extent, these individuals were working at what they had been sent to do.⁸

Arriving in the colony in January and April 1608 on vessels of the First Supply captained by Christopher Newport were goldsmiths William Johnson and Richard Belfield, refiners William Dawson and Abram Ransack and jeweller Daniel Stallings.⁹ Based upon Spain's New World experiences, the Virginia Company had high expectations that precious metals were to be found in Virginia, and the search for silver and gold was a priority in the colony's initial years. Some of the metalworking specialists arriving in 1608 may have been dispatched by the Goldsmith's Company after the first sample of 'gold' sent back to England in the previous year turned out to be 'so much gilded durt'.¹⁰ These faulty trials had been conducted at Jamestown under the direction of Captain John Martin, who is not recognized as having any special training in assaying beyond being the son of Sir Richard Martin, Master of the Royal Mint and, as a practising goldsmith, a member of the London Guild of the Goldsmiths' Company.

Subsequent support from the Goldsmiths' Company for more accurate tests is suggested by archival documentation from the Company's records that appear to reference the 1608 metalworkers. A Thomas Belfield (*sic*), listed as an apprentice goldsmith in 1580, may be the aforementioned Richard Belfield for, just one month before the Virginia Company supply fleet left Gravesend in September 1607, he was allocated 20s. by the Goldsmiths' Company to purchase a 'suit of apparel' for the Virginia voyage.¹¹ William Johnson may be the individual listed in the Goldsmiths' records in 1595 and 1602 as a 'smallworker' who took on apprentices in those years. If this is the same Johnson who ventured to Virginia in 1608, he had returned to London two years later when he is again recorded as signing on an apprentice. Finally, in 1620, a William Johnson is recorded in Goldsmiths' Company records as being 'one of 43 of the most ancient poor decayed workmen'.¹² It is not known for certain if these records are all referring to the same William Johnson, goldsmith, who was in the colony, but future documentary research may clarify this issue.

The jeweller, Daniel Stallings, is most likely the Danyell Stalling recorded in April 1605 as a 'foreigner' who was sworn to follow the ordinances of the Goldsmith's Company.¹³ If Stallings did not

subsidize his own travel to Virginia, he may have been recruited by the Virginia Company to survey the availability of gemstones or to work in consort with the colony's other metallurgists who were not focusing solely on precious metals. Research based on recent archaeological evidence for metallurgical trials in James Fort suggests that tests of Virginia's ores were made at the behest of the Society of Mines Royal and the Society of Mineral and Battery Works, of which many of the Virginia Company shareholders were investors and/or administrators. These two copper monopolies controlled a glut of copper derived from English sources and were interested in finding calamine stone in Virginia that was of the right purity for the extraction of zinc, a fundamental ingredient in the production of brass.¹⁴ Evidence of these trials, as well as of others, such as the search for noble metals and the manufacture of glass, has been found during the archaeological investigations. The distilling flasks, scorifiers, cupels, alembics and scores of high-quality Hessian crucibles from the fort's earliest contexts indicate the serious investment made by the investors into the extractive industries.¹⁵ These were not casual and unorganized efforts by a number of idle gentlemen. Rather, in the initial years of the settlement, trained specialists with well-equipped workshops were in place to engage in the tasks they had been assigned.

SAND CASTING MOULD

Supporting this point are two tools found during excavations of the fort that were most likely part of the goldsmiths' or the jeweller's equipment. Found in one of the postholes of a structure believed to be the church constructed in 1608 was an iron 'stirrup-shaped' sand casting mould (Fig. 3). Measuring 109mm from the flattened base to the rounded top, the mould, or casting flask, consists of two parts known as the cope and the drag that join by alignment pins on either side to create a frame without top or bottom around the pattern to be cast. The perimeters of both parts of the frame are lipped to contain the sand and a hole at the top of the mould is for pouring in the melted metal.¹⁶ These flasks for small-scale work took many shapes and required only that there was about a 12.7mm of clearance between the model to be cast and the sides of the frame.¹⁷ In fact, the 'stirrup-shaped' flask found at Jamestown is a type still used by jewellers and goldsmiths in modern times (Fig. 4).

The church, represented archaeologically by 14 postholes associated with a 64ft × 24ft (19.5m × 7.3 m) earthfast structure, was built between January and April 1608 by Captain Newport's mariners.¹⁸ Described by Captain John Smith as 'a



FIG. 3

Front and side views of an iron mould for sand casting found in a post hole of the c. 1608–17 church (photograph, Michael Lavin).

homely thing like a barne', the church stood with a number of subsequent repairs until 1617 when it was replaced by a new structure located several yards to the east.¹⁹ Some of the 1608 church post-holes were found to contain cobbles of Bermuda limestone, a material that was not present in Virginia until the survivors of the *Sea Venture* shipwreck on the Bermudas reached the colony in May 1610. After that date Bermuda limestone,

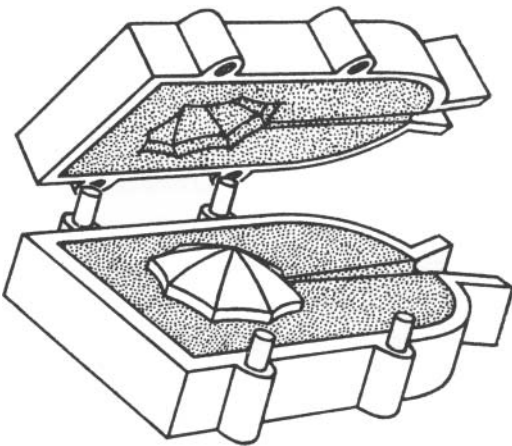

FIG. 4

Illustration of an octagonal brooch being cast in a mould similar to the one found in James Fort. From Prof. Dr. Erhard Brepohl 2001, *The Theory and Practice of Goldsmithing*, Brynmorgen Press. Used with permission.

which was recognized by the English colonists as 'the best in the world' for ballasting ships, was frequently supplied to the Jamestown settlement that had no natural stone.²⁰ Since the church support posts do not show signs of replacement, the post-1610 date of the posthole fill indicates that the structure was dismantled in 1617 when the new church was constructed. Rather than left to rot in place, posts were pulled out of the ground, providing the opportunity for the limestone and other materials to be shovelled into the empty holes.²¹ The casting flask could therefore either date to the church's 1608 construction or to this 1617 fill.

Gold was rarely cast in the early 17th century. The preferred metal for this process in decorative metalwork was silver or copper alloy and a possible product of the Jamestown sand casting mould is a crudely cut brass plaque rendered with a high relief 'pelican in her piety'²² (Fig. 5). The plaque measures 63mm × 40mm, which is quite within range of the 12.7mm clearance needed in the mould, which has interior dimensions of 86mm × 66mm. Found in the upper mixed layers of the 1608–10 fort well, the object dates to the early 17th century but its purpose is unknown. Even though the iconography is carefully rendered, showing the pelican with closed wings sitting in her nest above two chicks, the plaque has a roughly snipped



FIG. 5

Brass plaque cast with the iconography of the 'Pelican in her Piety', found in the c. 1608–10 well of James Fort (photograph, Michael Lavin).

irregular perimeter and appears to be unfinished. The object is pierced at the top, but at 54g it is very unlikely that it was meant to be a pendant in its present state. The 'pelican in her piety' had been used as a Christian symbol since the Middle Ages to represent Christ's sacrifice due to the belief that the pelican would wound itself and feed its young with its own blood rather than allow them to starve. It was a popular symbol in the late Tudor and early Stuart periods, as illustrated by the appropriation of the iconography by Elizabeth I to symbolize her role as 'mother' of the church of England. The pelican emblem also appears prominently at the bottom of the title page of the 1611 First Edition of the King James Bible.

The 'pelican in her piety' was commonly adopted in heraldry and is depicted as a decorative device on a wide variety of English material culture including needlework, monumental brasses, stained glass, pottery, medallions and personal signets. So, while the artefact may relate to the introduction of Protestantism to the New World, it could also have been commissioned as a decorative heraldic device by one of Jamestown's gentlemen. One such individual, William Cantrill (Cantrell, Chantrell) arrived in the colony in April 1608, possibly in the same ship as jeweller Daniel Stallings.²³ His family crest was the 'pelican in her piety' but, unlike the Jamestown imagery, the Cantrill pelican is depicted with elevated and addorsed wings, a difference that would be important in heraldic representations. Research continues on this unique artefact.

DRAWPLATE

Another tool belonging to either the jeweller or the goldsmiths is a drawplate found in the upper fill of an early fort-period workshop/bakery that, like the well, was backfilled in 1617 (Fig. 6).²⁴ The contemporaneous contexts of the drawplate and the casting flask, two objects related to the production of ornamental metalwork, suggest that the goldsmiths and jeweller may have been among the fort's casualties by 1617, and that further interest in assessing Virginia's metaliferous ores and producing objects from them had abated by this time.

Proclaimed by Geoff as 'a remarkable find', the drawplate is a 275mm long and 28mm wide iron bar terminating in points at each end for securing it in place. The body of the 4mm thick plate is perforated in three rows, each with a different decorative shape of half-moons, stars, and diamonds. Each shape is represented by seventeen graduated perforations from 1mm to 4mm in size for drawing metal wire through successively smaller holes until the desired dimension was reached (Fig. 7).

The size of the piercings on the plate indicates that the wire was not pulled by hand using a pair of pliers, but instead a piece of equipment called a drawbench was used.²⁵ As illustrated in a 1576 engraving depicting goldsmiths at work (Fig. 8), the drawplate would be fixed on one end of the long bench and a winch for pulling the wire would be placed on the other. Evidence for such an apparatus at Jamestown suggests that there was a 'well set up, local, specialist workshop' in the colony for the purpose of producing small decorative metal objects.²⁶ The exact location of this workshop has not been identified through excavation, but evidence that Johnson, Belfield and/or Stallings were practising their trades in the early colony is suggested by the cast brass unfinished pelican and by remnants of silver and copper alloy wire found adhering to the interiors of two of the perforations of the drawplate during conservation (Fig. 9).

'FLINGING OUT THEIR BEST METALWORK'

Geoff was always astonished by the types of small finds recovered from James Fort, which he considered of superior quality to the objects found in London excavations of the same time period. This led him to once remark that the colonists 'seem to have been remarkably profligate, flinging out their finest metalwork in readily handleable pieces'.²⁷ Geoff puzzled why so many remarkable artefacts were not better cared for or, at the very least, used as trade items with the Indians. A possible explanation for this unusual pattern at Jamestown was

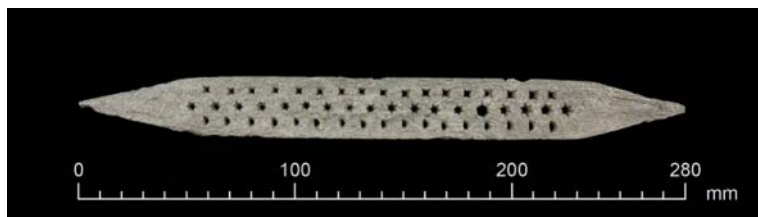

FIG. 6

Iron drawplate recovered from c. 1607–17 bakery/workshop of James Fort (photograph, Michael Lavin).

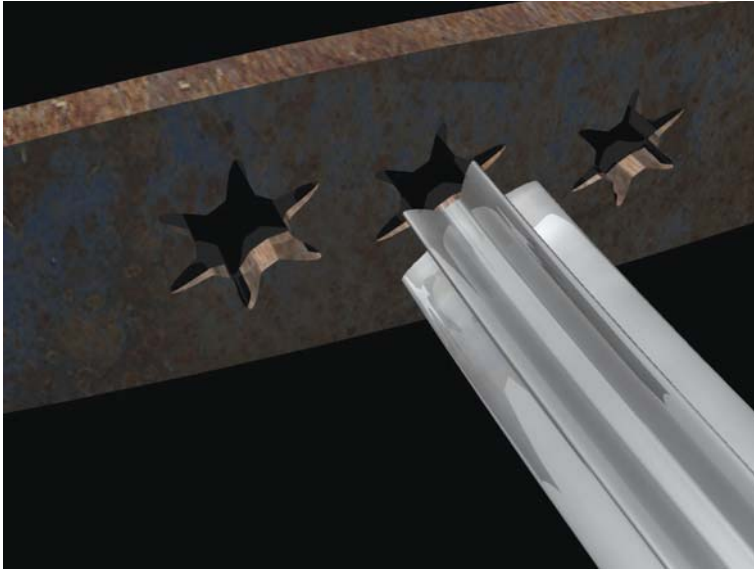

FIG. 7
Illustration of decorative wire created by pulling through star perforations on a drawplate (courtesy of Dr Jack Ogden).



FIG. 8
Engraving of a goldsmith's workshop; Étienne Delaune, 1576 (© Trustees of the British Museum).

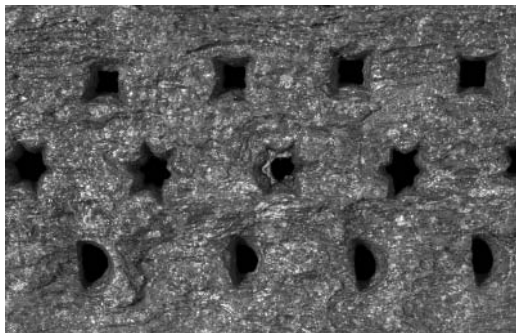

FIG. 9

Detail of the James Fort drawplate showing copper alloy wire adhering to the interior of the central star perforation (photograph, Michael Lavin).

proposed in the introduction of the present paper: it could well result from the combination of high mortality within an unstable population living in close quarters under very stressful conditions.

EAR PICK

One of the many special small finds found in the fort is a silver implement used for both adornment and personal cleanliness. As Geoff indicated in *Dress Accessories*, co-authored with Frances Pritchard, new rules of social etiquette that arose in the medieval period included attention to one's hygiene and resulted in a vast range of cosmetic implements devised to shape facial hair and to clean the nails, teeth and ears.²⁸ The teeth and ears received particular attention for, beyond any aesthetic reasons for cleanliness, it was recognized that a build-up of earwax could cause deafness, and medical professionals encouraged regular removal of the 'stone-like substance commonly called the scales or surf of the teeth'.²⁹

While earpicks could be quite plain and produced in bone, ivory or base metals, ornamental forms in gold and silver are also known. These cosmetic tools are found today in several European museum collections, and have been recovered archaeologically both from 16th-century English and Spanish shipwrecks and from terrestrial sites in England, Germany, Portugal, and North America.³⁰ Unlike their plainer cousins, the more decorative versions incorporate suspension loops for hanging from the owner's girdle or, as reflected in 16th-century Italian portraiture, about the neck (Fig. 10). Public personal display of gold and silver tools for hygiene, particularly toothpicks, became fashionable among post-medieval European elites



FIG. 10

Portrait of Lucia Brembati, Lorenzo Lotto c. 1518 (Accademia Carrara, Bergamo).

as signs of status and of their familiarity with the socially accepted behavioural code of cleanliness.

The decorative cosmetic implement recovered from James Fort is, as was the fashion for many of these tools, double-ended and multi-functional (Fig. 11). The ornate 57mm-long silver device has been cast in the form of a dolphin grasping between its teeth a round-sectioned nail/tooth cleaner that curves out to a point like a giant tusk. Since it is associated with a medicinal tool, the tusk may be representing the horn of a rhinoceros, long recognized for its remedial properties.³¹ Arching out from the creature's tail is a small scoop or 'eare-pick' for removing earwax.³² A suspension loop is incorporated into the dolphin's back, so that when the tool was worn by the owner the fish would be presented horizontally in the traditional heraldic *naiant* (swimming) position.

A similar silver toothpick/earscoop from North Yorkshire was recorded by the Portable Antiquities Scheme (PAS) (Fig. 12). The entry for this object, which is not curved into an S-shape like the James Fort example, describes the zoomorphic mid-section as a dragon, even though it most likely also illustrates a dolphin.³³ The dolphins depicted on both hygienic tools little resemble the real animal; contemporary heraldic and cartographic

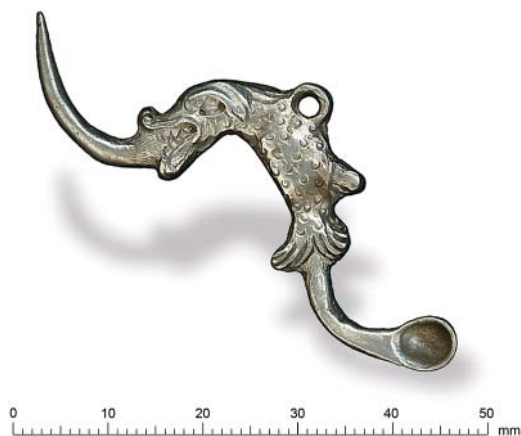

FIG. 11

Silver dolphin hygiene tool found in James Fort.

representations of the marine mammal took similar artistic liberties and reflect 'wide variety and latitude'.³⁴ Long an icon of the sea and recognized for aiding seafarers, the dolphin motif was probably chosen for these combination hygienic tools to appeal to gentlemen who spent a great deal of time at sea. This association is suggested by a gold example recovered from the *Girona*, a Spanish ship that went down in 1588 as part of the Armada.³⁵ On the other hand, sea creatures were popular subjects for jewellers, particularly in late 16th-century England when maritime supremacy was an accentuated aspect of public consciousness and voyages of exploration and discovery were proliferating.³⁶



FIG. 12

Silver hygiene tool found in North Yorkshire, recorded by the PAS (DUR-93A484).

At present, only two other ornamental tools for hygiene have been recognized from archaeological sites in North America, but neither incorporates the decorative complexity of the example from James Fort. One is a silver earscoop with a sickle-shaped toothpick from a c. 1620–35 settlement located thirty miles up the James River from Jamestown. Named Jordan's Journey, the settlement was home to several of the Virginia colony's prominent gentlemen and this status is reflected in the rest of the material culture.³⁷ The other North American find is a silver toothpick from a c. 1587–1680 Spanish mission, Santa Catalina de Guale, on St Catherine's Island, Georgia, where it is considered to be unusual and in 'contrast to the religious and institutionalized composition of the material assemblage'.³⁸ Despite colonial sumptuary laws, one individual apparently chose to indicate his status in the New World setting by wearing a silver toothpick in accordance with the established notions of decorum in elite Spanish society. Status indicators, such as the ear picker/toothpick, were probably even more important to individuals in the colonial settlements than they had been in their established European communities where their cultural standings were known. John Smith mentioned how difficult it was to choose the leaders of the Jamestown settlement since 'all were strangers to each others education, qualities, or disposition'.³⁹ Individuals used material goods as an expedient to negotiating interpersonal relationships by signalling their place in the new social and cultural milieu. Markers of Jamestown's elite, for instance, can be seen in the material record that includes high status items such as *façon de Venise* goblets, Chinese porcelain bowls, silver damascened sword hilts and gofferings irons for ironing neck ruffs. Even in the wilds of Virginia, it was important to exhibit symbols of one's standing in English society with the hopes that it would transfer without question to the new colonial community.

FINGER RINGS

Seventy finger rings have been recovered thus far during the excavations at James Fort. This number appears too large to be explained through random losses by Jamestown's inhabitants and instead may be a consequence of the colony's high rate of mortality mentioned earlier whereby many personal objects were rendered ownerless.⁴⁰ Of no interest to surviving colonists who themselves were prey to physical and psychological maladies, countless items ended up in the fort's trash deposits as a result of the periodic clean-up and rebuilding efforts.

Some of the finger rings, especially the 19 examples made of lead, may not have been

personal possessions but instead may have been brought to use in the Indian trade. These inexpensive base metal rings were produced in imitation of precious metal examples, either with false stones or with the hoop, bezel and the appearance of a setting cast in one piece (Fig. 13). London archaeological deposits suggest that the popularity of these mass-produced finger rings ended in the 15th century when jewellery made of precious metals became more widely accessible to the general public.⁴¹ The appearance of these objects at Jamestown, coupled with the fact that all but three of the rings were found in the same context of the fort's *c.* 1608–10 well, supports a purposeful bulk supply of finger rings as trade items. The well was filled with materials considered to have no value and that were discarded rather than loaded onto the ships during the attempted abandonment of the fort.

Only two of the finger rings recovered from Jamestown are gold. One found in the fort's

c. 1608–10 well matches a gold puzzle ring found in Staffordshire and recorded by the PAS as probably dating to the 18th or 19th centuries as there was 'no evidence to date this ring pre-1705'.⁴² Its similarity to the Jamestown ring, however, suggests that it too dates from the early 17th century. Both rings consist of three wavy interlinking hoops that, when turned the correct way, will fit together to form a twisted bezel (Fig. 14). Puzzle rings, consisting of multi-hoops that are permanently linked, are related to gimmel rings, which incorporated two hoops and were used as love rings. Although it is unknown as to how often it was practised, the idea was that one of the hoops would be worn by each of a betrothed couple until marriage; the two parts would then be joined again. Some gimmel rings pivoted apart making separation easy, but some required a jeweller to separate and join the hoops.⁴³ One hoop of the Jamestown ring bears a tiny heart, suggesting that it was not fashioned merely for amusement but was worn as a token of love.

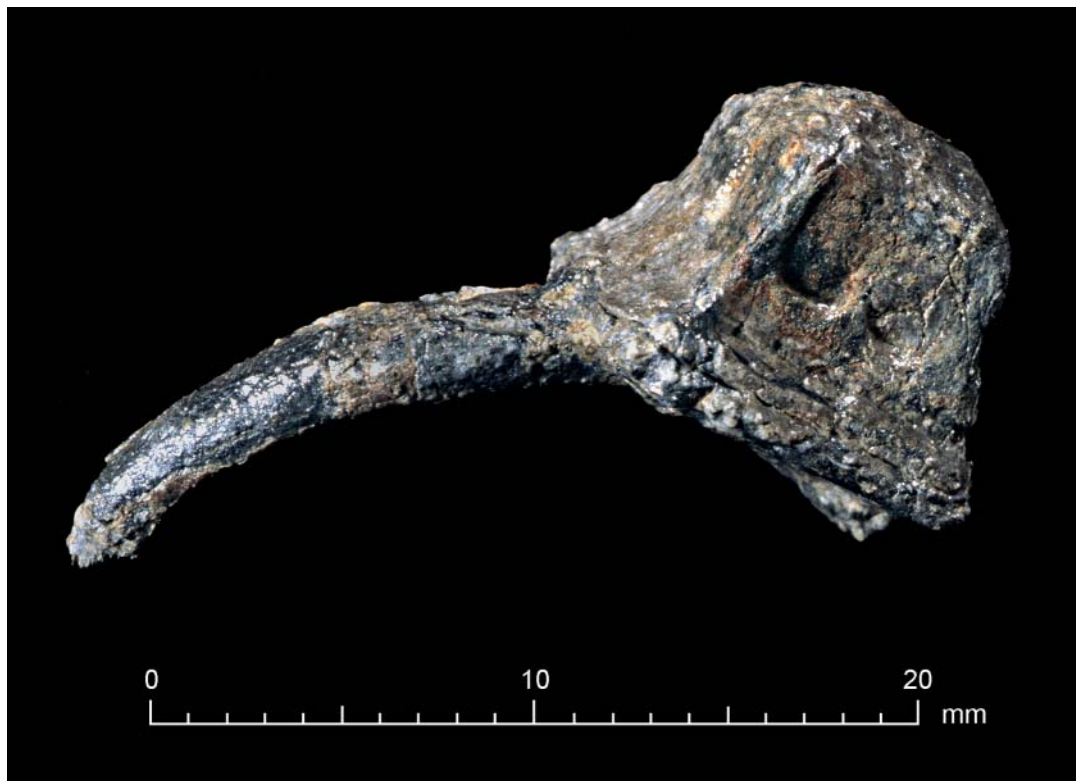

FIG. 13

Incomplete lead finger ring from a *c.* 1610 context of James Fort. Round-sectioned hoop, bezel and 6mm × 6mm square-cut setting cast in one piece (photograph, Michael Lavin).



FIG. 14
Gold puzzle ring found in
c. 1608–10 context of James
Fort (photograph, Michael
Lavin).

NATIVE PRESENCE

One particular research focus concerns understanding the relationship between the Jamestown colonists and the Virginia Indians as represented by the considerable quantity of Native material culture present in the fort features. The English had settled in the midst of an extensive Algonquin-speaking chiefdom of Powhatan Indians that encompassed 16,800 square kilometres of the Virginia Coastal Plain. The members of the chiefdom, who numbered about 15,000, were governed by a paramount chief called Wahunsenacawh, but known to the English by the same name as his people, Powhatan.⁴⁴ Evidence from the earliest fort contexts indicates that before the first organized

conflict between the English and the Powhatans began in the fall of 1609, there was both a significant Indian presence in the English settlement and an active exchange of goods. This commerce is well represented in the colonial contexts by at least 50 Virginia Indian shell-tempered clay cooking pots, most of which exhibit scorch marks or residues from cooking. Lipid analysis of residues from one pot indicated that it had once cooked typical Powhatan cuisine consisting of a meat (possibly venison) and corn (*Zea Mays*) stew.⁴⁵ This evidence combined with the appearance in the same fort contexts of lithic Native food preparation tools, such as pestles, nutting stones and hammer stones, suggests that either Indian techniques were adopted by the English to process and prepare

their meals or that there were Powhatan women present fulfilling these tasks. Interestingly, several of the Native clay pots feature a flattened base, which appears to be a deliberate modification of the traditional rounded form to accommodate the English use of pots on tables.

Women were the potters in Powhatan society, as well as the artificers of a good deal of the material culture including shell beads, grass mats that the colonists used to 'dress their chambers and inward rooms' and baskets.⁴⁶ The soft-sided grass baskets were the usual containers for corn and other foodstuffs the Indians were trading to the colonists and, although not surviving in the archaeological contexts, were probably very common in the fort. Fortunately, one Indian basket was used by a colonist to model a container in another medium by pushing and smoothing clay into the basket's interior (Fig. 15). Recovered from a c. 1610 context, the 254mm tall vessel with 17mm thick walls had probably been pit-fired over low heat, which served to burn off the basket. The imprint of finely woven twined fibre left on the exterior of the basket resembles dogbane (*Apocynum cannabinum* L.), the local hemp plant that the colonists observed the Virginia Indians using to make cordage.⁴⁷

Although it has not yet been chemically tested, visual inspection of the 'basket pot' fabric indicated that it is unlike Powhatan shell-tempered



FIG. 15

Clay pot produced by using a grass Indian basket as a model, found in a c. 1610 fort context (photograph, Michael Lavin).

wares. Rather, the fabric appears similar to the clay used by colonist Robert Cotton, 'tobacco-pipe-maker', who arrived at Jamestown in April 1608 and whose pipes are abundant in the fort's earliest contexts.⁴⁸ Cotton's basket pot could represent an easy solution for a container to replace a broken imported vessel, or it could reflect an Englishman's appreciation for Powhatan basketry and his desire to preserve it in a more permanent form. Virginia exotica, including aboriginal material culture, were of great interest among the English gentry and made prized gifts for the colonists to send home. King James, for example, had little enthusiasm for Virginia once precious metals failed to materialize; nevertheless, he was still 'earnestly' desirous of receiving a Virginia flying squirrel. Also illustrative of this interest in unusual things from Virginia is colonist Francis Perkins' 1608 shipment to English acquaintances that included turtle doves, ears of corn, sassafras and two Indian 'pots of our ordinary earth'.⁴⁹

The recent archaeological evidence from James Fort is contributing to a richer understanding of the initial cultural interactions between the English and the Powhatans than has ever been derived from the historic record. With the documents all written by the English, the historical emphasis has concerned the settlers' use of European goods to trade for much-needed food and to socialize the Virginia Indians to their advantage. Now, the vast collection of Native material culture in the fort indicates a greater level of inter-cultural mingling in the English settlement than has ever been previously realized.⁵⁰ Powhatan artefacts, and indications that some of these materials were being produced on-site, support the presence of both Indian men and women in the fort supplying the English with goods. For a brief period the material worlds of the two groups blended as the English tried to subdue the Indians to their will and chief Powhatan attempted to incorporate the English into his paramourty.

CHILDREN: EVIDENCE OF THE UNRECORDED

During the early period of settlement, Jamestown was a predominately male settlement with women and children rarely documented except in association with their adult male relatives. One hundred men and four cabin boys or pages were recorded by Captain John Smith as the first settlers in May 1607. Seventeen months later, the first women — a maidservant and her mistress — arrived at Jamestown in the company of the gentlewoman's husband. These two remained the colony's only women until August 1609 when a fleet of seven

ships brought family units that included 30 to 50 women and children, although only a handful of these individuals are known to us by name. The presence of the colony's women and children is occasionally detected in the material record, although this can be somewhat arbitrary. Few objects at the time were gender-specific, and toys that would characterize childhood were often made of organic materials that do not survive most soil conditions. In addition, toys, or small objects of little value, were used by the colonists as trade items for the Indians and cannot be definitively ascribed to the existence of children.

TOY WINDMILL

One such 'trifle' is a copper-alloy toy windmill found in a c. 1610 trash pit within the fort (Fig. 16). If it belonged to a child, it must be associated with one of the children who had sailed to Jamestown aboard the aforementioned 1609 fleet.

Geoff Egan, an acknowledged authority and author on early playthings found in London, proclaimed this 3cm-tall replica of a post mill as very unusual for 17th-century toys found in the City, especially in its robustness.⁵¹ The only other known freestanding toy post mill from the period was found in the Netherlands, which may also be the source of the Jamestown object.⁵² Toy windmills were common playthings and in their earliest form consisted of wooden sticks with paper sails that rotated in the wind. By the 16th century, windmills were made with spring-activated sails that could be worked by pulling a string.⁵³ Upon release of the string it would be rewound by the spring, making it ready to pull again and thereby providing hours of interactive play for child or adult. Even though it has now lost its sails, the Jamestown windmill was probably this type of spring-loaded toy with the string wrapping around a now-missing rod through the sail aperture in the roofline.

TEETHING STICK

Unquestionably belonging to one of the fort's youngest citizens is an object that was found in a well located in the fort's centre. This context is believed to have been backfilled during historically documented events in early June 1610 that were initiated by a temporary abandonment of the settlement. As the colonists prepared to leave, they engaged in large-scale dumping of materials considered not valuable enough to take back to England. The well continued to be filled with fort debris through the major clean-up and rebuilding efforts ordered by the new governor who re-established the colony just 36 hours later.



FIG. 16

Brass toy windmill recovered from a James Fort trash pit filled c. 1610 (photograph, Michael Lavin).

The artefact is a combination whistle and teething stick composed of decorated sheet silver wrapped with two rings of spiralled silver wire jingles. One end of the stick still secures a small piece of the Mediterranean red coral teether (Fig. 17). Coral was used right up through the 19th century to help ease the gum pain of children who were teething, not only because the smooth hard substance was comforting but also because coral was thought to have apotropaic qualities. By incorporating coral in a toy for teething infants, it was hoped that the children could be spared the mortality commonly associated with this particularly



FIG. 17

Silver teething stick from the c. 1608–10 well of James Fort (photograph, Michael Lavin).

vulnerable time of life. The weaning process not only included the stresses of gum pain and dietary changes but also exposed the child to pathogens ‘which lurked unrecognised in the beakers, bowls, and spoons made of metal, wood or horn’.⁵⁴ Coral’s efficacy in the protection of children was a long-held belief, as indicated by Pliny’s statement that ‘the branches of coral hung about the necks of infants and young children are thought to be a sufficient preservative against all witchcraft and sorcerie’.⁵⁵

The silver body of the Jamestown teething stick is only 61mm long, which appears to be indicative of its early date. Later 17th-century sticks, as depicted in the 1630 portrait of King Charles II (Fig. 18) and those made in the 18th and 19th centuries tend to be larger, ranging in length from 76mm to 203mm, and often incorporate a number of rumbler bells.⁵⁶ A few early 17th-century teething sticks have been reported to the Portable Antiquities Scheme (PAS) although, lacking their coral ends, they were misidentified as huntsmen’s whistles (Fig. 19).⁵⁷ The close similarity of these objects to the Jamestown example, however, suggests that originally they also once belonged to early 17th-century children as teething sticks.

It may never be known who once possessed the Jamestown teething stick, or why it was thrown away, but the silver object most assuredly belonged to one of the handful of children that were part of high-status families arriving at Jamestown by 1610. Documentary and genealogical research will continue to focus on the gentlemen who were known to be in the colony during the first three years for evidence they may have been joined by their families that could have included young children.



FIG. 18

King Charles II by unknown artist (© National Portrait Gallery, London).

CONCLUSION

The items described in this discussion are just a few of the wonderful surprises from the Jamestown soil, and with excavations continuing on the fort



FIG. 19

Silver teething stick (IOW-954403) recorded by the PAS as an early 16th-century huntsman’s whistle.

and its environs there will inevitably be more to contribute towards understanding England's first successful transatlantic colony. During the first 20 years of excavation, annual funding for the Jamestown Rediscovery project was uncertain and, out of necessity, resources were applied to data gathering by archaeologically defining as much of the fort as possible and by cataloguing and conserving the finds. Now that the project is on firmer financial footing, energies will focus on researching the artefact assemblage and producing comprehensive studies on a broad range of themes that should be relevant to all colleagues who are studying the cusp of the Jacobean age.

ACKNOWLEDGEMENTS

Blacksmiths Mark Atchison and Peter Ross were the first to suggest that our 'mystery' object from the 1608 church posthole was a sand-casting flask, and I am extremely grateful to them for this insight. Their initial identification led to stimulating discussions with metalsmith and publisher Tim McCreight, and with goldsmiths Prof. Dr Erhard Brepohl and Dr Jack Ogden, all of whom patiently answered my questions and shared my enthusiasm for uncovering evidence of the first goldsmiths and jeweller at Jamestown. I am also indebted to David Beasley, Librarian of the Goldsmiths' Company, who provided important references from the Company records and suggestions for further investigation. As is often the way, research 'down the rabbit hole' began exposing some interesting and important leads regarding the specialist metalworkers at Jamestown that appeared too late to incorporate in this paper, but will form the basis of a future study.

Finally, special acknowledgement and gratitude must be extended to the late Geoff Egan who will always be recognized for his assistance in helping to identify and contextualize the James Fort finds as well as for his enthusiastic and unwavering support for the work of the Jamestown Rediscovery project.

NOTES

¹ Findings of the Jamestown Rediscovery Project can be accessed through the dig updates of the Historic Jamestowne website (<www.historicjamestowne.org>). Information is also available in Kelso and Straube 2004; Kelso 2006; Straube 2006; 2007.

² Kupperman 1979.

³ Egan 2007.

⁴ Egan 1999; Egan 2005, 1–3; Egan & Forsyth 1997, 215–16.

⁵ Recent borings of ancient stands of Bald Cypress trees near Jamestown have revealed that the area suffered the worst drought in almost a millennium between 1606 and 1612 (Stahle *et al.* 1998, 564–7).

⁶ Smith 1986c, 272.

⁷ Morgan 1975, 71–91.

⁸ Morgan 1975, 84–6; Straube 2004.

⁹ Smith 1986a, 222.

¹⁰ Smith 1986b, 158.

¹¹ Forsyth 2007, 127; David Beasley, pers. comm.

¹² David Beasley, pers. comm. based upon notes by Gerald Taylor.

¹³ Goldsmiths' Court Minute Book O, 19 April 1605, 392.

¹⁴ Hudgins 2005.

¹⁵ For centuries, Hessian crucibles were considered to be of the best quality (Cotter 1992, 265).

¹⁶ McCreight 1994, 81.

¹⁷ Tim McCreight, pers. comm.

¹⁸ Wingfield 1998 [1608], 196.

¹⁹ Smith 1986c, 295; Lounsbury 2004, 3–5.

²⁰ Lefroy 1882, 284–5.

²¹ Historic Jamestowne 2011, Where We Are Digging Now, <http://historicjamestowne.org/the_dig/dig_2011_07_13.php> [last modified 13 July 2011].

²² Jack Ogden, pers. comm.

²³ Smith 1986b, 161.

²⁴ Kelso *et al.* 2012, 7–26.

²⁵ Jack Ogden, pers. comm.

²⁶ Jack Ogden, pers. comm.

²⁷ Geoff Egan, pers. comm.

²⁸ Egan & Pritchard 1991, 377.

²⁹ Holme 1688, III(11); Allen 1997 [1686], 131.

³⁰ Leal & Ferreira 2008; Deagan 2002, 230–1; MacLean 2009, 125–39; Richards 2005, 161.

³¹ Ivor Noël Hume, pers. comm.

³² Woodall 1978, 17–18.

³³ PAS, <<http://finds.org.uk/database/artefacts/record/id/403003>> [accessed 30 October 2013].

³⁴ Fox-Davies 1996, 253.

³⁵ Flanagan 1988, 199.

³⁶ Evans 1970, 110–13.

³⁷ McCartney 2011, 74–8.

³⁸ MacLean 2009, 134.

³⁹ Smith 1986a, 213.

⁴⁰ Of the estimated 6,000 people venturing to Virginia during the Virginia Company years (1607–24), only 1,200 individuals remained to be listed in the colony's 1625 census (Kupperman 1979, 24).

⁴¹ Egan & Pritchard 1991, 334; Egan & Forsyth 1997, 229.

⁴² Rudoe, 2008, 171.

⁴³ Oman 1993, 19.

⁴⁴ Potter 1994, 14–24.

⁴⁵ Reber 1999.

⁴⁶ Strachey 1973, 81.

⁴⁷ Spelman 1998, 492.

- ⁴⁸ Smith 1986b, 162.
- ⁴⁹ Earl of Southampton 1969, 288; Perkins 1969, 161.
- ⁵⁰ Straube 2013.
- ⁵¹ Geoff Egan, pers. comm.; see Forsyth & Egan 2005.
- ⁵² Forsyth & Egan 2005, 393.
- ⁵³ Forsyth & Egan 2005, 393.
- ⁵⁴ Abbott 1996, 55.
- ⁵⁵ Pliny *Historie of the World*, as quoted in Spaulding & Welch 1994, 166.
- ⁵⁶ Ball 1961.
- ⁵⁷ See also file numbers OW2009-T222 and NCL-E5B597 (<<http://finds.org.uk/database>> [accessed 30 October 2013]).
- BIBLIOGRAPHY**
- Abbott, M. 1996, *Life Cycles in England 1560–1720: Cradle to Grave*, New York: Routledge.
- Allen, C. 1997 [1686], *Curious Observations on the Teeth*, in Picard 1997, 131.
- Ball, B. 1961, 'Whistles with coral and bells', *The Magazine Antiques* **80**, 552–5.
- Barbour, P.L. 1986, *The Complete Works of John Smith (1580–1631)*, 3 vols, Chapel Hill: The University of North Carolina Press.
- Barbour, P.L. 1969, *The Jamestown Voyages Under the First Charter 1606–1609*, 2 vols, Cambridge: University Press.
- Barton, C. & Hitchcock, F. (eds) 2008, *Treasure Annual Report 2005/6*, London: Department for Culture, Media and Sport.
- Cotter, J. 1992, 'The mystery of the Hessian wares, post-medieval triangular crucibles', in Gaimster & Redknapp 1992, 262–72.
- Deagan, K. 2002, *Artifacts of the Spanish Colonies of Florida and the Caribbean, 1500–1800*, **2**, Washington, DC: Smithsonian Institution Press.
- Earl of Southampton 1969 [1609], 'Letter from the Earl of Southampton to the Earl of Salisbury, 15 December 1609', in Barbour 1969 (2), 288.
- Egan, G. 2007, 'Building a new world: digging up Jamestown', *Brit. Archaeol.* **95** (July/August).
- Egan, G. 2005, *Material Culture in London in an Age of Transition: Tudor & Stuart Period Finds c 1450–c 1700 from Excavations at Riverside Sites in Southwark*, MoLAS Monograph **19**.
- Egan, G. 1999, 'London, axis of the Commonwealth? An archaeological review', in Egan & Michael 1999, 61–71.
- Egan, G. & Michael, R.L. (eds) 1999, *Old and New Worlds*, Oxford: Oxbow Books.
- Egan, G. & Forsyth, H. 1997, 'Wound wire and silver gilt: changing fashions in dress accessories c. 1400–c. 1600', in Gaimster & Stamper 1997, 215–38.
- Egan, G. & Pritchard, F. 1991, *Dress Accessories. Medieval Finds from Excavations in London: 3*, London: HMSO.
- Evans, J. 1970, *A History of Jewellery 1100–1870*, reprint, Mineola, NY: Dover Publications.
- Flanagan, L. 1988, *Ireland's Armada Legacy*, Gloucester: Alan Sutton Publishing.
- Forsyth, H. 2007, 'Earth's only paradise: adventures in Virginia', *Goldsmith's Rev.*, 10–15.
- Forsyth, H. & Egan, G. 2005, *Toys, Trifles and Trinkets*, London: Unicorn Press.
- Fox-Davies, A.C. 1996, *Complete Guide to Heraldry*, Hertfordshire: Wordsworth Editions.
- Gaimster, D. & Stamper, P. 1997, *The Age of Transition: the Archaeology of English Culture 1400–1600*, The Society for Medieval Archaeology Monograph **15**, Oxbow Monograph **98**.
- Gaimster, D. & Redknapp, M. 1992, *Everyday and Exotic Pottery from Europe c. 650–1900*, Oxford: Oxbow.
- Gardiner, J. (ed.) 2005, *Before the Mast: Life and Death Aboard the 'Mary Rose'*, Portsmouth: The Mary Rose Trust Ltd.
- Haile, E.W. 1998, *Jamestown Narratives*, Champlain, Virginia: Roundhouse.
- Hansen, S. & Meyer, M. (eds) 2013, *Parallele Raumkonzepte*, Topoi: Berlin Studies of the Ancient World **16**.
- Hitchcock, F. (ed.) 2007, *Treasure Annual Report 2004*, London: Department for Culture, Media and Sport.
- Holme, R. 1688, *The Academy of Armory: or a storehouse of armory and blazon*, in 4 books, Chester: Printed for the Author.
- Hudgins, C.C. 2005, 'Elizabethan Industries in Jacobean Virginia? An Examination of the Industrial Origins and Metallurgical Functions of Scrap Copper at Early Jamestown (c. 1607–1610)', Holloway College, University of London PhD thesis.
- Kelso, W.M. 2006, *The Buried Truth*, Charlottesville: The University of Virginia Press.
- Kelso, W. M. & Straube, B. 2004, *Jamestown Rediscovery 1994–2004*, Richmond: The Association for the Preservation of Virginia Antiquities.
- Kelso, W.M., Straube, B., & Schmidt, D. (eds) 2012, '2007–2010 Interim Report on the Preservation Virginia Excavations at Jamestown, Virginia', Jamestown, Virginia: Association for the Preservation of Virginia Antiquities.
- Kupperman, K. 1979, 'Apathy and death in early Jamestown', *J. Am. Hist.* **66**:1, 24–40.
- Lefroy, J.H. (ed.) 1882, *The Historie of the Bermudaes or Summer Islands*, London: The Hakluyt Society.

- Leal, C.C., Ferreira, M.A. 2008, 'Hygienic nail-cleaners, toothpicks and ear-scoops from a monastic Portuguese context', *J. Iberian Archaeol.* **11**, 71–98.
- MacLean, J.S. 2009, 'Mission Santa Catalina's mondadiente de plata (silver toothpick): materiality and the construction of self in Spanish La Florida', in White 2009, 125–39.
- McCartney, M. 2011, *Jordan's Point, Virginia*, Richmond: University Press of Virginia.
- McCreight, T. 1994, *Practical Casting*, Cape Elizabeth, Maine: Brynmorgen Press.
- Morgan, E.S. 1975, *American Slavery, American Freedom*, New York: W.W. Norton and Company.
- Oman, C.C. 1993, *Victoria and Albert Museum Catalogue of Rings 1930*, Suffolk: Anglia Publishing.
- Perkins, F. 1969 [1608] 'Letter from Francis Perkin[s] in Jamestown to a friend in England, 28 March 1608', in Barbour 1969, 158–62.
- Picard, L. 1997, *Restoration London*, London: Weidenfeld and Nicholson.
- Potter, S.R. 1994, *Commoners, Tribute and Chiefs: the Development of Algonquian Culture in the Potomac Valley*, Charlottesville: University Press of Virginia.
- Richards, M. 2005, 'Personal hygiene and sanitary arrangements', Gardiner 2005, 153–62.
- Rudoe, J.A. 2008, 'Ilam, Staffordshire: 18th- or 19th-century gold puzzle ring (92005T518)', in Barton & Hitchcock 2008, 171.
- Smith, J. 1986a [1612], 'The proceedings of the English Colonie in Virginia', in Barbour 1986, **1**: 191–289.
- Smith, J. 1986b [1624], 'The Generall Historie of Virginia, New-England, and the Summer Iles', in Barbour 1986, **2**: 5–477.
- Smith, J. 1986c [1631], 'Advertisements for the Unexperienced Planters of New England, or Any Where', in Barbour 1986, **3**: 254–307.
- Spaulding, M. & Welch, P. 1994, *Nurturing Yesterday's Child*, Toronto: Natural Heritage/Natural History.
- Spelman, H. 1998 [1609], 'Relation of Virginia, 1609', in Haile 1988, 482–95.
- Stahle, D.W., Cleaveland, M.K., Blanton, D.B., Therrell, M.D., & Gay, D.A. 1998, 'The lost colony and Jamestown droughts', *Science* **280**, 564–67.
- Strachey, W. 1973 [1609] 'A True Reportory', in Wright 1973, 1–101.
- Straube, B. 2013, 'An English settlement in Tsenacomoco', in Hansen & Meyer 2013, 17–39.
- Straube, B. 2007, *The Archaearium: Rediscovering Jamestown 1607–1699*, Richmond, VA: Preservation Virginia.
- Straube, B. 2006, "'Unfitt for any moderne service"? Arms and armour from James Fort', *Post-Medieval Archaeol.* **40**:1, 33–61.
- Straube, B. 2004, 'Tinker, Tailor, Soldier, Sailor', in Kelso & Straube 1994, 155–92.
- White, C.L. (ed.) 2009, *The Materiality of Individuality*, New York: Springer.
- Wingfield, E.M. 1998 [1608], 'A Discourse of Virginia', in Haile 1998, 183–201.
- Woodall, J. 1978 [1617], *The Surgions Mate*, reprint with foreword by John Kirkup, Bath: Kingsmead.
- Wright, L.B. (ed.) 1973, *A Voyage to Virginia in 1609*, Charlottesville: University Press of Virginia.

SUMMARY IN FRENCH, GERMAN, ITALIAN AND SPANISH

RÉSUMÉ

Surprises sorties du sol: découvertes archéologiques de la première colonie trans-atlantique établie avec succès à Jamestown

La culture matérielle provenant du fort « James Fort » établi en 1607 en Virginie, et du site d'établissement de la colonie anglaise de Jamestown, apporte de nouvelles informations intéressantes sur la première implantation. Les objets découverts reflètent non seulement l'interaction des colons avec les indiens de Virginie, mais aussi les activités des experts envoyés dans le but de détourner les ressources du Nouveau Monde au profit des investisseurs de la colonie, ainsi que les choix des individus concernant les biens domestiques qui les ont accompagnés lors de leur voyage au-delà de l'Atlantique.

ZUSAMMENFASSUNG

Überraschung in der Erde: archäologische Entdeckung in Englands ältester erfolgreichen, transatlantischen Kolonie in Jamestown

Die materiellen Funde aus Jamestown in Virginia, gegründet in 1607 auf dem ursprünglichen Gelände der englischen Jamestown Kolonie, deckten neue und interessante Information über den frühen Ort auf. Die Objekte weisen auf wechselseitige Beziehungen mit den Virginia Indianern hin: zum einen durch die Handlungen der in die Neue Welt gesandten Spezialisten, die Rohstoffe der Neuen Welt in Profit für die kolonialen Investoren verwandelten, zum anderen durch die Wahl der Haushaltsgüter, die über den Atlantik geschifft wurden. Die Gruppe der Artefakte ist überraschend wegen ihrer Dichte und auch, dass viele der Objekte atypisch im Kontext eines englischen Haushalts des frühen 17. Jahrhunderts sind.

*RIASSUNTO***Soprese dal suolo: scoperte archeologiche dalla prima colonia inglese che prosperò al di là dell'Atlantico, Jamestown**

La cultura materiale di James Fort in Virginia, fondato nel 1607, e il sito dove inizialmente sorse la colonia inglese di Jamestown, sta rivelando nuove e interessanti informazioni sulle fasi più antiche dell'insediamento; gli oggetti riflettono l'interazione dei coloni con gli Indiani della Virginia, le attività di specialisti inviati a trasformare le risorse del Nuovo Mondo in profitto per gli investitori delle colonie, nonché le scelte fatte da singoli individui nell'atto di trasportare suppellettili domestiche al di là dell'Atlantico.

*RESUMEN***Las sorpresas que nos da el suelo: descubrimientos arqueológicos de la primera colonia transatlántica de Inglaterra que prosperó en Jamestown**

Tanto la cultura material del Fuerte James de Virginia, fundado en 1607, como la de la colonia inglesa de Jamestown está proporcionando nuevos e interesantes datos sobre el asentamiento primitivo en esta zona. Los objetos reflejan tanto la interacción de los colonos con los indios de Virginia, como las actividades de los especialistas enviados al Nuevo Mundo para transformar sus recursos en beneficio de los colonos inversores, así como el tipo de selección personal de las mercancías domésticas que se transportaban al otro lado del Atlántico.

*Jamestown Rediscovery, 1365 Colonial Parkway, Jamestown, Virginia 23081, USA
[bly@preservationvirginia.org]*